

# KENWOOD

## KSC-SW10

---

POWERED ENCLOSED SUBWOOFER

### INSTRUCTION MANUAL

CAISSON D'EXTRÊME GRAVE AMPLIFIÉ

### MODE D'EMPLOI

GEKAPSELTER SUBWOOFER MIT VERSTÄRKER

### BEDIENUNGSANLEITUNG

SUBWOOFER MET SPANNINGSCIRCUIT

### GEBRUIKSAANWIJZING

SUBWOOFER CON AMPLIFICATORE E CASSA

### ISTRUZIONI PER L'USO

ALTAVOZ DE SUBGRAVES CON CERRADO ALIMENTACION

### MANUAL DE INSTRUCCIONES

УСИЛЕННЫЙ ЗАКРЫТЫЙ САБВУФЕР

### ИНСТРУКЦИЯ ПО ЭКСПЛУАТАЦИИ



AE86

Kenwood Corporation

© B61-1319-00/00 (W) KW

ENGLISH

FRANÇAIS

DEUTSCH

NEDERLANDS

ITALIANO

ESPAÑOL

РУССКИЙ

# IMPORTANT SAFETY INSTRUCTIONS

**⚠ Caution: Read this page carefully to ensure safe operation.**

## ⚠ WARNING

- Before mounting or wiring etc., be sure to remove the wire from the battery minus terminal.  
(Not doing so can cause shorts or fires.)
- When extending the ignition, battery, or ground wires, make sure to use automotive-grade wires or other wires with a 0.75mm<sup>2</sup> (AWG18) or more to prevent wire deterioration and damage to the wire coating.
- To prevent a short circuit, never put or leave any metallic objects (such as coins or metal tools) inside the speaker.
- In the event the unit generates smoke or abnormal smell, immediately switch the power OFF. After this, please contact your dealer or nearest service station as soon as possible.

### POWER OFF!

- Connect the illumination lamp-equipped speakers to DC 12V, negative ground.
- Do not attempt to open or modify the unit, for this could cause fire hazard or malfunction.
- After taking the unit out of the polyethylene bag, be sure to dispose of the polyethylene bag out of the reach of children. Otherwise, they may play with the bag, which could cause hazard of suffocation.

## ⚠ CAUTION

- Installation and wiring of the product requires expert skill and experience. To ensure safety, be sure to have your dealer or specialist perform the installation and wiring.
- Do not install the speaker in a spot exposed to direct sunlight or excessive heat or humidity.
- Do not install the speakers in locations which may be subject to water or moisture.
- Do not install the speakers in unstable locations or locations subject to dust.
- If the fuse blows, after checking to see if the wiring cord has shorted, be sure to replace with the stipulated size (amperage) fuse as displayed on the fuse box.  
(Using fuses other than the stipulated size can cause fires.)

### Check the display!

To replace the fuse, refer to the vehicle instruction manual.

- To prevent a short circuit when replacing a fuse, disconnect the wiring harness at first.
- Do not use gasoline, naphtha, or any type of solvent to clean the speaker. Clean by wiping with a soft, dry cloth.
- Connect the speaker wires to appropriate speaker connectors separately. Sharing the negative wire of the speaker or grounding speaker wires to the metal body of the car can cause this unit to fail.
- Do not connect cables and leads to both RCA cord input jacks and the speaker input terminals simultaneously, for this may cause malfunction or damage.
- When making a hole under a seat, inside the trunk, or somewhere else in the vehicle, check that there is nothing hazardous on the opposite side such as a gasoline tank, brake pipe; or wiring harness, and be careful not to cause scratches or other damage.
- For ground wire mounting, do not fasten the wire to an airbag, steering or brake line system or other critical safety unit bolts or nut.  
(Can cause accidents.)
- When mounting, be sure to mount in a place that will not interfere with driving or be dangerous to passengers during sudden braking etc.  
(Cause of injury or accidents.)
- After installing the unit, check to make sure that electrical equipment such as the brake lamps, turn signal lamps and windshield wipers operate normally.

## Information on Disposal of Old Electrical and Electronic Equipment (applicable for EU countries that have adopted separate waste collection systems)



Products with the symbol (crossed-out wheeled bin) cannot be disposed as household waste.

Old electrical and electronic equipment should be recycled at a facility capable of handling these items and their waste by products.

Contact your local authority for details in locating a recycle facility nearest to you.

Proper recycling and waste disposal will help conserve resources whilst preventing detrimental effects on our health and the environment.



## Declaration of Conformity with regard to the EMC Directive 2004/108/EC

### Manufacturer:

Kenwood Corporation  
2967-3 Ishikawa-machi, Hachioji-shi, Tokyo,  
192-8525 Japan

### EU Representative's:

Kenwood Electronics Europe BV  
Amsterdamseweg 37, 1422 AC UITHOORN,  
The Netherlands





## For your records

Record the serial number, found on the back of the amplifier, in the spaces designated on the warranty card, and in the space provided below. Refer to the model and serial numbers whenever you call upon your dealer for information or service on this product.

Model : KSC-SW10

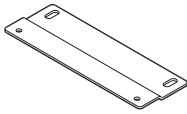
Serial Number : \_\_\_\_\_

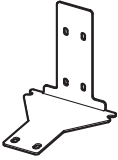
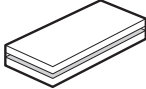
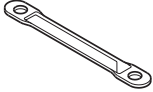
# Parts included

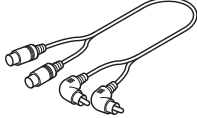
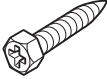
No.	Part Name	Outside Shape	Quantity	No.	Part Name	Outside Shape	Quantity
①	Fixture A		2	⑥	10-pin connector cord (6 m / 19 ft)		1
②	Fixture B		2	⑦	Velcro tape (Double-side adhesive/ for Remote control)		1
③	Fixture C		1	⑧	Remote control (6 m / 19 ft)		1
④	Machine screw (M4 x 6)		8	⑨	RCA cord (0.5 m / 1.6 ft)		1
⑤	Tapping screw ( $\varnothing$ 5 x 16)		6				

# Connection

## ⚠ Caution:

Before wiring, be sure to remove the wire from the negative terminal of the battery. After completing all wiring, check the correct wirings again. After checking, connect the wire from the negative terminal of the battery.

## Terminals of Subwoofer

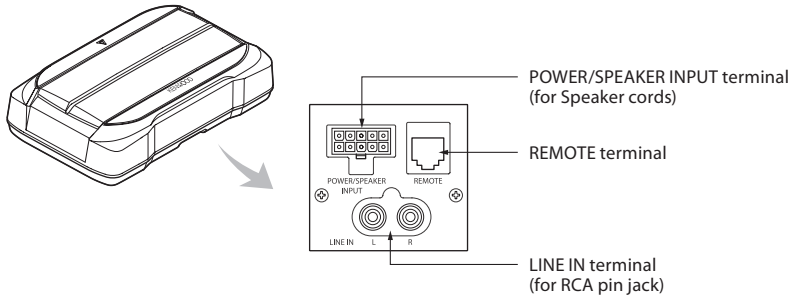

## Connecting the remote control unit

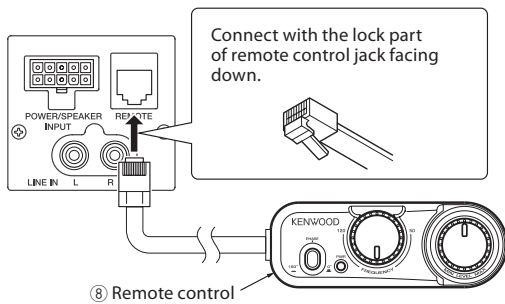

### Notes:

- If the cord is not connected properly, the power indicator on the remote control unit and the illumination on the main unit do not light up.
- If the remote control unit is not connected properly or at all, the subwoofer does not output the sound.
- Do not insert the remote control connector upside down or forcibly. Otherwise, malfunction may result.

# Connecting the subwoofer to the speaker output of the center unit with built-in amplifier

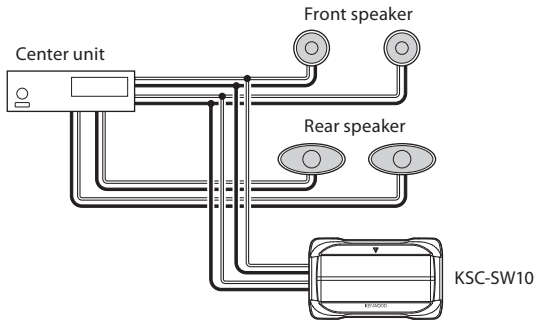

**Connect the subwoofer to the front or rear output cords of the center unit.**

**Note:**  
Read the instruction manuals for the connected components such as the center unit as well as this instruction manual.

ENGLISH

## Examples

The following shows a typical connection for effective car stereo enjoyment. Connect your system by referring to the example.

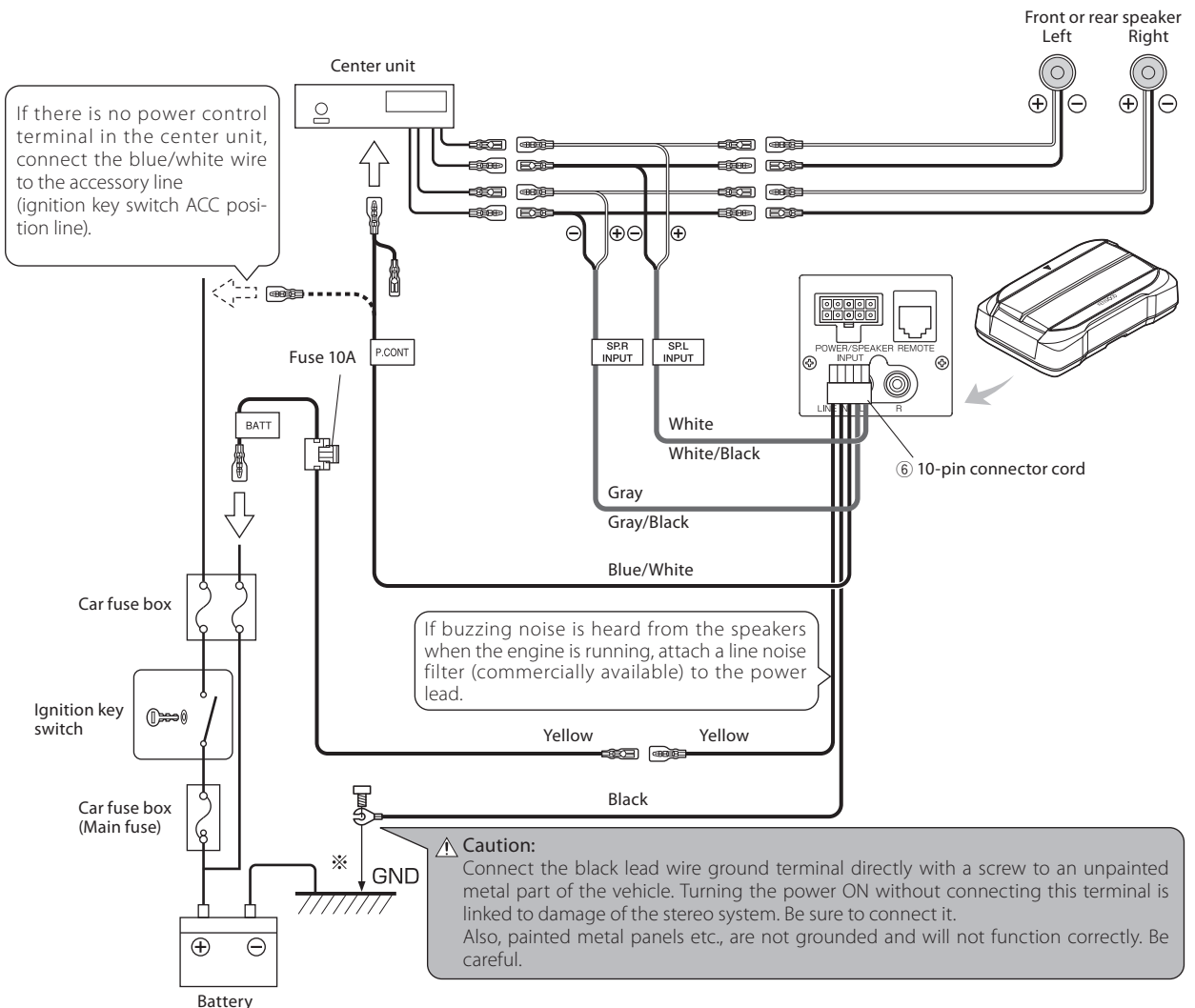

## Connecting the subwoofer to the subwoofer (non-fader) output of the center unit

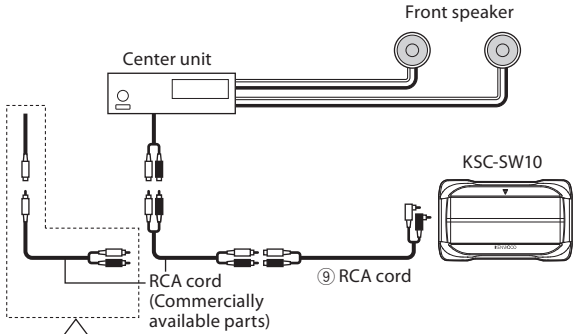

When the center unit output is a single RCA jack, use an RCA cord that converts the output into the two RCA jacks as shown above. The subwoofer output will be halved if the conversion cord is not used.

**Connect the subwoofer to the subwoofer output (non-fader output) or the RCA jacks for the front output of the center unit.**

- Notes:**
- Read the instruction manuals for the connected components such as the center unit as well as this instruction manual.
  - Please purchase an RCA cord that is commercially available separately. Use the provided RCA cord ⑨ for connection between the subwoofer and the separately purchased RCA cord.
  - When the center unit incorporates a DSP, connect the subwoofer to the subwoofer output (non-fader output) or to the RCA jacks for the front output. Do not connect to the RCA jacks for the rear output, as the low-frequency reproduction effect may be attenuated due to the DSP effect.

## Examples

The following shows a typical connection for effective car stereo enjoyment. Connect your system by referring to the example.

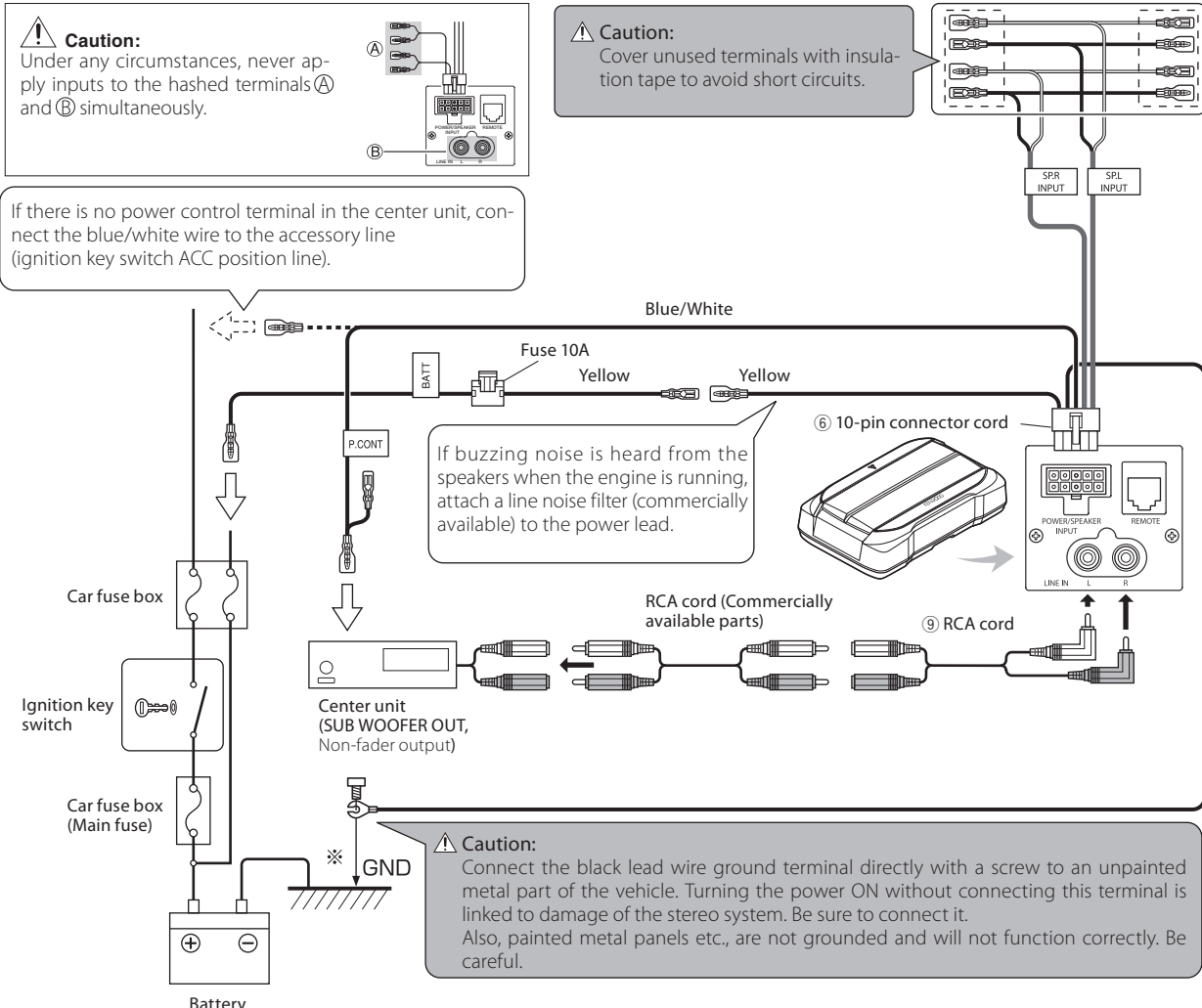

# Installation

Before fixing the speaker in its position, be sure to check the sound while it is connected preliminary.

## ⚠ Caution:

- Install in a location that does not come in the way of driving, getting in or out of the vehicle and movement inside the vehicle compartment.
- Fix the product firmly so that it will not be moved by vibrations or impacts during driving.

## Fixing the cord in place

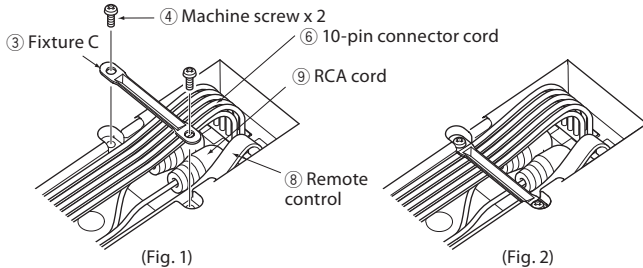

- 1 Connect the 10-pin connector cord ⑥, RCA cord ⑨, and remote control ⑧ to the speaker unit. (Fig. 1) (When connecting the speaker input terminal, RCA cord is not necessary.) (The cords to be connected depends on the system. Refer to Connection of example.)
- 2 Fix the cords to the speaker unit with fixture C ③, and fix in place with the machine screws ④. (Fig. 2)

## Fixing the subwoofer

### Flat installation

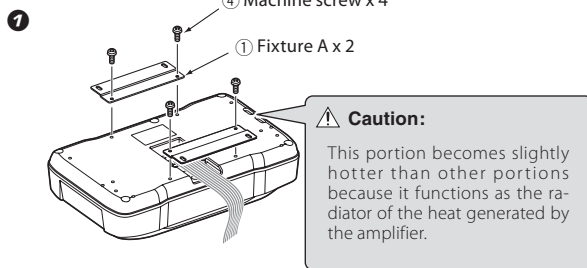

Attach the fixtures A ① to the speaker unit securely using the machine screws ④. Be careful so that the connected cords do not get in between the speaker unit and fixtures A ①.

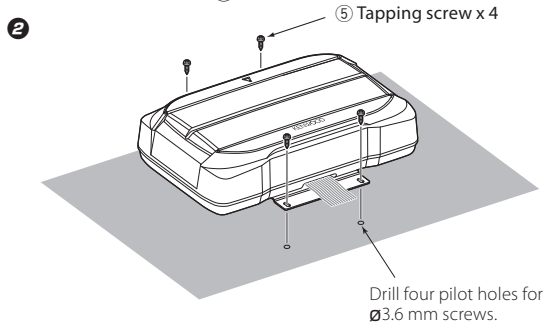

Drill the pilot holes for  $\varnothing 3.6$  mm screws on the sheet metal section of the vehicle, and attach the speaker unit to the vehicle using the tapping screws ⑤.

### Side installation

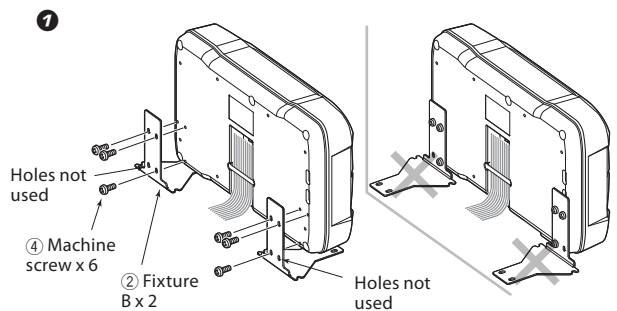

Adjust the installation height so that the speaker unit will not rattle, and attach the bracket B ② to the subwoofer using the machine screws ④.

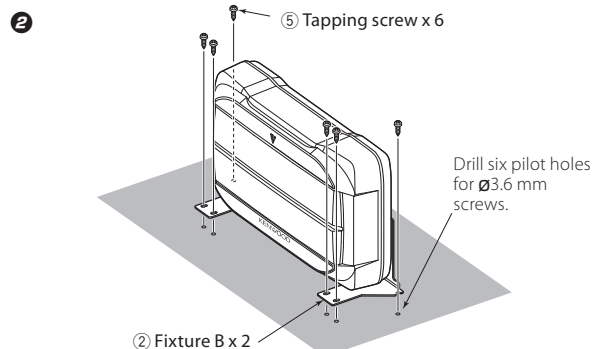

Drill the pilot holes for  $\varnothing 3.6$  mm screws on the sheet metal section of the vehicle, and attach the speaker unit to the vehicle using the tapping screws ⑤.

## Installing the remote control unit

Install the remote control unit on the vehicle by the provided Velcro tape.

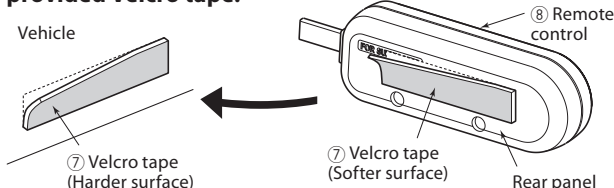

## ⚠ Caution:

Install the remote control unit in a position that does not come in the way of driving operations. Avoid installing it in a place subject to direct sunlight or direct hot wind from the heater. Otherwise, the product may be degraded and a fire hazard may result. Remove dirt from the installation position before attaching the Velcro tape. When the Velcro tape is attached on the remote control unit, it cannot be accommodated in the main unit.

# Operation

## Name of each part (Remote control)

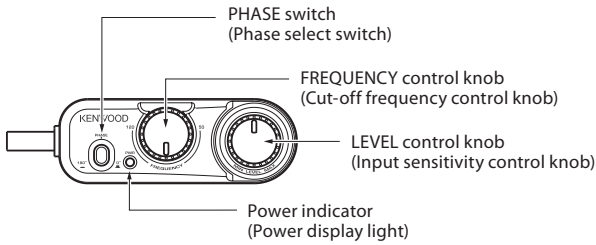

The illumination on the subwoofer turns on and off in an interlocked operation with the PWR indicator on the remote control unit.

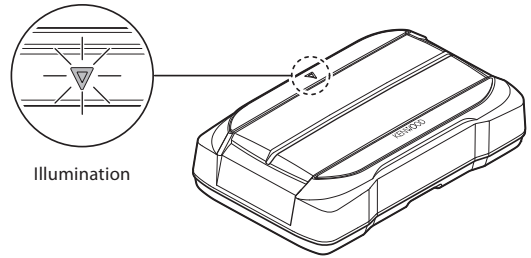

### Power indicator

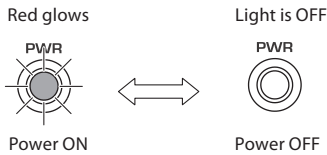

## Adjusting the sound (Remote control operation)

- 1 Turn the **FREQUENCY control knob** to adjust the cut-off frequency (frequencies higher than this frequency are cut off).

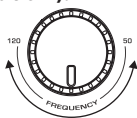

Turn the **FREQUENCY control knob** to adjust the balance between the bass from the rear speakers and the bass from this unit as desired.

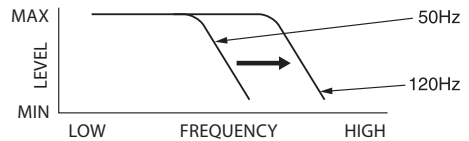

- 2 Turn the **LEVEL control knob** to adjust the low frequencies to the desired level.



- 3 Adjust the low frequency phase.

The low frequency tone may be variable depending on the position of the unit, its orientation or the turn-over frequency. This can be adjusted by changing the position of the **PHASE switch**. Set this switch to either position according to your liking. [[0°] indicates the normal phase and [180°] means the reverse phase.

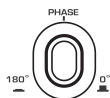

## Fuse exchange

Exchange with the specified capacity fuse.

**Caution:** Be sure to replace with same capacity (amperage) as displayed on the fuse. This product is 10A.

### Removal

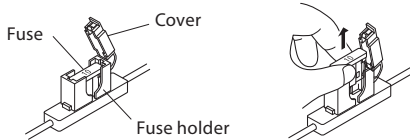

- 1 Open the cover.
- 2 Grasp with pliers and pull up.

### Insertion

Replacement fuse 10 A

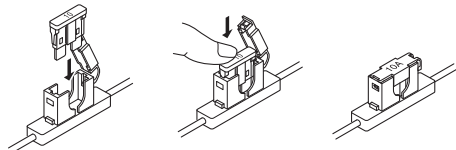

- 1 Insert the fuse gently into the fuse holder and push in all the way with your finger.
- 2 Close the cover.



